

DEMU FIXING ANCHORS T-FIXX®

EUROPEAN TECHNICAL APPROVAL ETA-13/0222



DEMU FIXING ANCHORS

ETA_T-FIXX 05/13-E

CONCRETE



HALFEN
YOUR BEST CONNECTIONS

DEMU FIXING ANCHORS T-FIXX

General note

Use of third-party products

This approval only applies to original HALFEN products manufactured by HALFEN. The specifications in this approval are not transferable to other products. Users are fully liable for personal injuries and material damage caused by third-party products used instead of HALFEN products.

Deutsches Institut für Bautechnik

Zulassungsstelle für Bauprodukte und Bauarten

Bautechnisches Prüfamt

Eine vom Bund und den Ländern
gemeinsam getragene Anstalt des
öffentlichen Rechts

Kolonnenstraße 30 B
D-10829 Berlin
Tel.: +49 30 78730-0
Fax: +49 30 78730-320
E-Mail: dibt@dibt.de
www.dibt.de

Deutsches
Institut
für
Bautechnik

DIBt

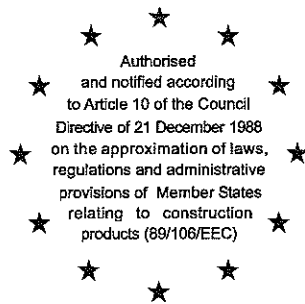

Mitglied der EOTA
Member of EOTA

European Technical Approval ETA-13/0222

English translation prepared by DIBt - Original version in German language

Handelsbezeichnung
Trade name

DEMU Hülsenanker T-FIXX
DEMU Fixing anchor T-FIXX

Zulassungsinhaber
Holder of approval

Halfen GmbH
Liebigstraße 14
40764 Langenfeld
DEUTSCHLAND

**Zulassungsgegenstand
und Verwendungszweck**
*Generic type and use
of construction product*

Einbetonierter Anker mit Innengewindehülse
Cast-in anchor with internal threaded socket

Geltungsdauer: vom
Validity: from
bis
to

8 May 2013
8 May 2018

Herstellwerk
Manufacturing plant

Werk Utrecht
Atoomweg 1
3542 Utrecht
Niederlande

Diese Zulassung umfasst
This Approval contains

16 Seiten einschließlich 9 Anhänge
16 pages including 9 annexes



Europäische Organisation für Technische Zulassungen
European Organisation for Technical Approvals

I LEGAL BASES AND GENERAL CONDITIONS

- 1 This European technical approval is issued by Deutsches Institut für Bautechnik in accordance with:
 - Council Directive 89/106/EEC of 21 December 1988 on the approximation of laws, regulations and administrative provisions of Member States relating to construction products¹, modified by Council Directive 93/68/EEC² and Regulation (EC) N° 1882/2003 of the European Parliament and of the Council³;
 - *Gesetz über das In-Verkehr-Bringen von und den freien Warenverkehr mit Bauprodukten zur Umsetzung der Richtlinie 89/106/EWG des Rates vom 21. Dezember 1988 zur Angleichung der Rechts- und Verwaltungsvorschriften der Mitgliedstaaten über Bauprodukte und anderer Rechtsakte der Europäischen Gemeinschaften (Bauproduktengesetz - BauPG) vom 28. April 1998⁴, as amended by Article 2 of the law of 8 November 2011⁵;*
 - Common Procedural Rules for Requesting, Preparing and the Granting of European technical approvals set out in the Annex to Commission Decision 94/23/EC⁶.
- 2 Deutsches Institut für Bautechnik is authorized to check whether the provisions of this European technical approval are met. Checking may take place in the manufacturing plant. Nevertheless, the responsibility for the conformity of the products to the European technical approval and for their fitness for the intended use remains with the holder of the European technical approval.
- 3 This European technical approval is not to be transferred to manufacturers or agents of manufacturers other than those indicated on page 1, or manufacturing plants other than those indicated on page 1 of this European technical approval.
- 4 This European technical approval may be withdrawn by Deutsches Institut für Bautechnik, in particular pursuant to information by the Commission according to Article 5(1) of Council Directive 89/106/EEC.
- 5 Reproduction of this European technical approval including transmission by electronic means shall be in full. However, partial reproduction can be made with the written consent of Deutsches Institut für Bautechnik. In this case partial reproduction has to be designated as such. Texts and drawings of advertising brochures shall not contradict or misuse the European technical approval.
- 6 The European technical approval is issued by the approval body in its official language. This version corresponds fully to the version circulated within EOTA. Translations into other languages have to be designated as such.

¹ Official Journal of the European Communities L 40, 11 February 1989, p. 12
² Official Journal of the European Communities L 220, 30 August 1993, p. 1
³ Official Journal of the European Union L 284, 31 October 2003, p. 25
⁴ *Bundesgesetzblatt Teil I 1998*, p. 812
⁵ *Bundesgesetzblatt Teil I 2011*, p. 2178
⁶ Official Journal of the European Communities L 17, 20 January 1994, p. 34

II SPECIFIC CONDITIONS OF THE EUROPEAN TECHNICAL APPROVAL

1 Definition of product and intended use

1.1 Definition of the construction product

The DEMU Fixing anchor T-FIXX in the size of M10, M12, M16 and M20 is an anchor consisting of an internal threaded socket deformed at one end.

The socket is made of galvanised steel or stainless steel.

The anchor may be imbedded surface-flush or sunk in the concrete.

An illustration of the product and intended use is given in Annex 1.

1.2 Intended use

The anchor is intended to be used for anchorages for which requirements for mechanical resistance and stability and safety in use in the sense of the Essential Requirements 1 and 4 of Council Directive 89/106/EEC shall be fulfilled and failure of anchorages made with these products would cause risk to human life and/or lead to considerable economic consequences.

The anchor is to be used only for anchorages subject to static or quasi-static loading in reinforced or unreinforced normal weight concrete of strength classes C20/25 at minimum to C50/60 at most according to EN 206-1:2000-12. The anchor may be anchored in cracked and non-cracked concrete.

The anchor may be used for transmission of tensile loads, shear loads or a combination of tensile and shear loads.

The anchor made of galvanised steel in combination with screws made of steel may only be used in structures subject to dry internal conditions. The anchor made of stainless steel in combination with screws made of stainless steel may also be used in structures subject to external atmospheric exposure (including industrial and marine environment) or exposure to permanently damp internal conditions, if no particular aggressive conditions exist. Such particular aggressive conditions are e.g. permanent, alternating immersion in seawater or the splash zone of seawater, chloride atmosphere of indoor swimming pools or atmosphere with extreme chemical pollution (e.g. in desulphurization plants or road tunnels where de-icing materials are used).

The anchor made of galvanised steel may only be used if the inner area of the socket is protected against water during installation.

The provisions made in this European technical approval are based on an assumed working life of the anchor of 50 years. The indications given on the working life cannot be interpreted as a guarantee given by the producer, but are to be regarded only as a means for choosing the right products in relation to the expected economically reasonable working life of the works.

2 Characteristics of the product and methods of verification

2.1 Characteristics of the product

The anchor corresponds to the drawings and information given in Annex 2 to 4. The characteristic material values, dimensions and tolerances of the anchor not indicated in the Annexes shall correspond to respective values laid down in the technical documentation⁷ of this European technical approval.

Regarding the requirements concerning safety in case of fire it is assumed that the anchor meets the requirements of class A1 in relation to reaction to fire in accordance with the stipulations of the Commission decision 96/603/EC, amended by 2000/605/EC.

The characteristic values for the design of the anchorages are given in Annexes 6 and 7.

The anchor shall be marked with the identifying mark of the producer, the name of the anchor, the size and additionally with the letters "GV" for galvanised steel or "A4" for stainless steel, e.g. "DEMU T-FIXX M10x50 GV" according to Annex 3.

2.2 Method of verification

2.2.1 General

The assessment of the fitness of the anchor for the intended use with regard to the requirements of mechanical resistance and stability as well as safety in use in the sense of the Essential Requirements 1 and 4 was performed based on the following verifications:

Verifications for tension loads for

- | | |
|---|-----------------------------|
| 1. Steel failure | $N_{Rk,s}$ |
| 2. Steel failure - transfer of setting torque into prestressing force | T_{inst} |
| 3. Concrete failure - pullout | $N_{Rk,p}$ |
| 4. Concrete failure - concrete cone | $N_{Rk,c}$ |
| 5. Concrete failure - splitting due to installation | $c_{min}, s_{min}, h_{min}$ |
| 6. Concrete failure - splitting due to loading | $N_{Rk,sp}$ |
| 7. Displacement under tension loads | δ_N |

Verifications for shear loads for

- | | |
|-------------------------------------|--------------|
| 1. Steel failure without lever arm | $V_{Rk,s}$ |
| 2. Steel failure with lever arm | $M_{Rk,s}^0$ |
| 3. Concrete failure - pry-out | $V_{Rk,cp}$ |
| 4. Concrete failure - concrete edge | $V_{Rk,c}$ |
| 5. Displacement under shear loads | δ_V |

In addition to the specific clauses relating to dangerous substances contained in this European technical approval, there may be other requirements applicable to the products falling within its scope (e.g. transposed European legislation and national laws, regulations and administrative provisions). In order to meet the provisions of the Construction Products Directive, these requirements need also to be complied with, when and where they apply.

⁷

The technical documentation of this European technical approval is deposited at Deutsches Institut für Bautechnik and, as far as it is relevant to the tasks of the approved body involved in the attestation of conformity procedure, is handed over to the approved bodies.

3 Evaluation and attestation of conformity and CE marking

3.1 System of attestation of conformity

According to the Decision 96/582/EC of the European Commission⁸ system 2(i) (referred to as system 1) of the attestation of conformity applies.

This system of attestation of conformity is defined as follows:

System 1: Certification of the conformity of the product by an approved certification body on the basis of:

- (a) Tasks for the manufacturer:
 - (1) factory production control;
 - (2) further testing of samples taken at the factory by the manufacturer in accordance with a prescribed test plan;
- (b) Tasks for the approved body:
 - (3) initial type-testing of the product;
 - (4) initial inspection of factory and of factory production control;
 - (5) continuous surveillance, assessment and approval of factory production control.

Note: Approved bodies are also referred to as "notified bodies".

3.2 Responsibilities

3.2.1 Tasks for the manufacturer

3.2.1.1 Factory production control

The manufacturer shall exercise permanent internal control of production. All the elements, requirements and provisions adopted by the manufacturer shall be documented in a systematic manner in the form of written policies and procedures, including records of results performed. This production control system shall insure that the product is in conformity with this European technical approval.

The manufacturer may only use initial/raw/constituent material stated in the technical documentation of this European technical approval.

The factory production control shall be in accordance with the control plan which is part of the technical documentation of this European technical approval. The control plan is laid down in the context of the factory production control system operated by the manufacturer and deposited with Deutsches Institut für Bautechnik.⁹

The results of factory production control shall be recorded and evaluated in accordance with the provisions of the control plan.

3.2.1.2 Other tasks for the manufacturer

The manufacturer shall, on the basis of a contract, involve a body which is approved for the tasks referred to in section 3.1 in the field of anchors in order to undertake the actions laid down in section 3.2.2. For this purpose, the control plan referred to in sections 3.2.1.1 and 3.2.2 shall be handed over by the manufacturer to the approved body involved.

The manufacturer shall make a declaration of conformity, stating that the construction product is in conformity with the provisions of this European technical approval.

⁸ Official Journal of the European Communities L 254 of 08.10.1996

⁹ The control plan is a confidential part of the European technical approval and only handed over to the approved body involved in the procedure of attestation of conformity. See section 3.2.2.

3.2.2 Tasks for the approved bodies

The approved body shall perform the

- initial type-testing of the product,
- initial inspection of factory and of factory production control,
- continuous surveillance, assessment and approval of factory production control,

in accordance with the provisions laid down in the control plan.

The approved body shall retain the essential points of its actions referred to above and state the results obtained and conclusions drawn in a written report.

The approved certification body involved by the manufacturer shall issue an EC certificate of conformity of the product stating the conformity with the provisions of this European technical approval.

In cases where the provisions of the European technical approval and its control plan are no longer fulfilled the certification body shall withdraw the certificate of conformity and inform Deutsches Institut für Bautechnik without delay.

3.3 CE marking

The CE marking shall be affixed on each packaging of the anchor. The letters "CE" shall be followed by the identification number of the approved certification body, where relevant, and be accompanied by the following additional information:

- the name and address of the producer (legal entity responsible for the manufacture),
- the last two digits of the year in which the CE marking was affixed,
- the number of the EC certificate of conformity for the product,
- the number of the European technical approval,
- size.

4 Assumptions under which the fitness of the product for the intended use was favourably assessed

4.1 Manufacturing

The European technical approval is issued for the product on the basis of agreed data/information, deposited with Deutsches Institut für Bautechnik, which identifies the product that has been assessed and judged. Changes to the product or production process, which could result in this deposited data/information being incorrect, should be notified to Deutsches Institut für Bautechnik before the changes are introduced. Deutsches Institut für Bautechnik will decide whether or not such changes affect the approval and consequently the validity of the CE marking on the basis of the approval and if so whether further assessment or alterations to the approval shall be necessary.

4.2 Design of anchorages

The fitness of the anchor for the intended use is given under the following condition:

The design of the anchorage is based on the CEN/TS 1992-4:2009 "Design of fastenings for use in concrete", part 1 and 2 under the responsibility of an engineer experienced in anchorages and concrete work.

The screw is chosen with corresponding screw-in depth acc. Annex 4, Table 4 and strength class acc. Annex 6 and 7 subject to the required steel resistance.

The member thickness is not less than h_{min} . The edge distance of the anchors is not less than c_{min} . The spacing of the anchors is not less than s_{min} . All these values are indicated in Annex 5, Table 5 subject to the size of the anchor.

Taking into account the loads to be anchored verifiable calculation notes and drawings are generated.

The position, the name, the size of the anchor, if applicable the supplementary reinforcement and the size, the screw-in depth and the strength class of the screw are indicated on the design drawings. The material of the anchor and the screw shall be given additionally on the drawings.

4.3 Installation of the anchor

The fitness for use of the anchor can only be assumed, if the following installation conditions are observed:

- Installation by appropriately qualified personnel and under the supervision of the person responsible for technical matters on site.
- Use of the anchor only as supplied by the manufacturer without any manipulation or exchanging the components.
- Installation in accordance with the manufacturer's specifications given in Annex 8 and 9 and the design drawings.
- The anchors are fixed on the formwork so that no movement of the anchors will occur during the time of laying the reinforcement and of placing and compacting the concrete.
- The concrete among the anchor and especially under the head of the anchor is properly compacted. The sockets are to be protected from penetration of concrete, for sockets made of galvanised steel of water into the internal space of the sockets.
- Size, material and strength class of screws corresponding to the design drawings.
- Observation of the prescribed values (e.g. T_{inst} according Annex 4) of installation.
- The setting torques given in Annex 4 must not be exceeded.

5 Responsibility of the manufacturer

It is in the responsibility of the manufacturer to ensure that the information on the specific conditions according to 1 and 2 including Annexes referred to and 4.2 and 4.3 is given to those who are concerned. This information may be made by reproduction of the respective parts of the European technical approval. In addition all installation data shall be shown clearly on the package and/or on an enclosed instruction sheet, preferably using illustration(s).

The minimum data required are:

- Dimensions of the anchor,
- Material of the socket,
- Mentioning the matching screw,
- Details on the installation procedure, preferably by using illustrations,
- Maximum setting torque,
- Identification of the manufacturing batch.

All data shall be presented in a clear and explicit form.

Uwe Bender
Head of Department

beglaubigt:
Müller

DEMU T-FIXX

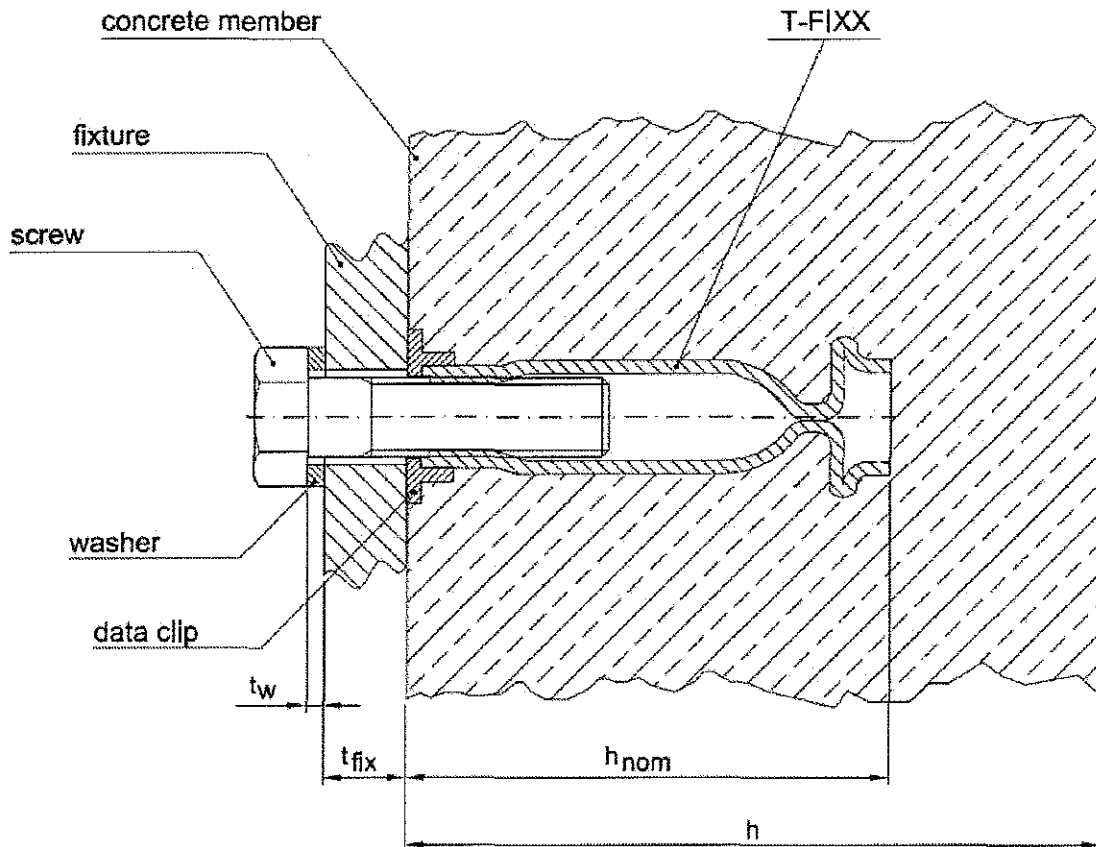

h = thickness of concrete member

t_{fix} = thickness of fixture

t_w = thickness of washer

h_{nom} = embedment depth

DEMU Fixing anchor T-FIXX

Product and intended use

Annex 1

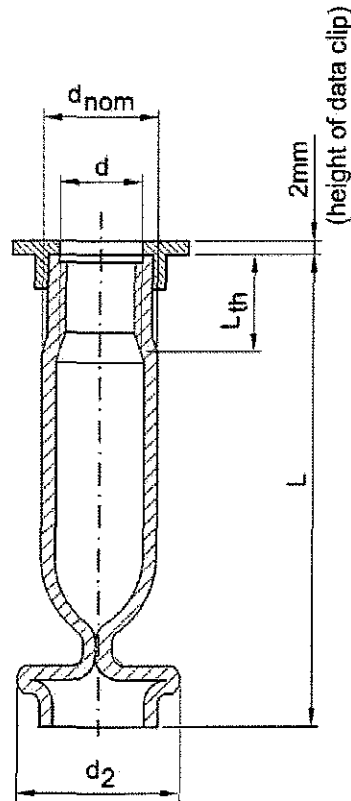

There are two different materials available for the DEMU Fixing anchor T-FIXX:

Material 1: Fixing anchor in galvanised steel

Material 2: Fixing anchor in stainless steel

Table 1: Dimensions of DEMU Fixing anchor T-FIXX

d	d _{nom}		L _{th}	d ₂		L	
	Material 1	Material 2		Material 1	Material 2	Material 1	Material 2
Thread [mm]	[mm]	[mm]	[mm]	[mm]	[mm]	[mm]	[mm]
M10	13.5	13.5	10.4 - 13.6	18.1	17.3	50 / 75	50 / 65
M12	17.0	17.2	12.5 - 16.1	23.0	23.0	50 / 70 / 95	50 / 70 / 115
M16	21.3	21.3	16.1 - 22.1	29.1	28.0	60 / 100 / 125	60 / 80 / 110
M20	26.9	26.9	20.2 - 27.6	34.7	33.5	70 / 100 / 145	70 / 100 / 125

DEMU Fixing anchor T-FIXX

Dimensions

Annex 2

Marking:
e.g.: DEMU T-FIXX M10x50 GV
DEMU: identifying mark of the producer
T-FIXX: name of the anchor
M10x50: size
GV: material
Material:
GV: galvanised steel
A4: stainless steel

Table 2: Specification and material of fixing anchor

Item	Component	Material 1	Material 2
		Fixing anchor in galvanised steel (GV)	Fixing anchor in stainless steel (A4)
1	Fixing anchor	E 235 +N (1.0308) acc. EN 10305-3, galvanised ¹⁾	stainless steel 1.4401 / 1.4404 / 1.4571 acc. EN 10217-7
2	Dataclip	for fixing anchor made of material 1: for fixing anchor made of material 2:	HDPE / RAL 7035 / (light-) grey HDPE / RAL 9003 / (signal-) white

Table 3: Specification and material of fixing components / suppl. reinforcement (not included with the fixing system)

Appr. Component	Material for use with fixing anchors made of material 1	Material for use with fixing anchors made of material 2
	Washer	Steel acc. EN 10025, galvanised ¹⁾ Dimensions acc. EN ISO 7089/7093-1
Screw	Steel acc. EN ISO 898-1, galvanised ¹⁾ , strength grade 4.6, 5.6 or 8.8	Stainless steel 1.4401 / 1.4404 / 1.4571 acc. EN ISO 3506-1, strength grade A4-50, A4-70 or A4-80
Suppl. reinforcement	B500A or B500B Detailing acc. CEN/TS 1992-4:2009	Stainless reinforcement steel 1.4571 / 1.4362 / 1.4462 respect. B500A or B500B meeting the requirements for concrete cover c_{nom} acc. EN1992-1

¹⁾ thickness of coating $\geq 5\mu\text{m}$ acc. EN ISO 4042

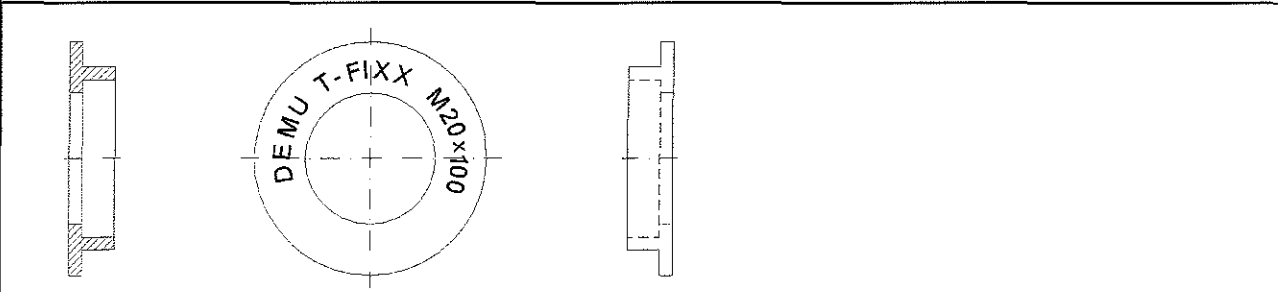

Data clip: section, top view (with example for marking) and side view

DEMU Fixing anchor T-FIXX	Annex 3
Marking and materials	

Direct contact between fixture and data clip

The fixture is braced to the data clip, if necessary by suitable washers.

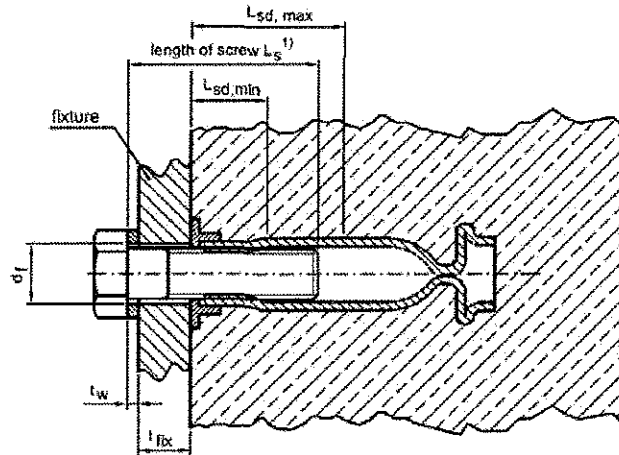

$$1) t_w + t_{fix} + L_{sd,min} \leq L_s \leq t_w + t_{fix} + L_{sd,max}$$

General application

The fixture is braced to the concrete, the fixing anchor being embedded flush or recessed in the concrete.

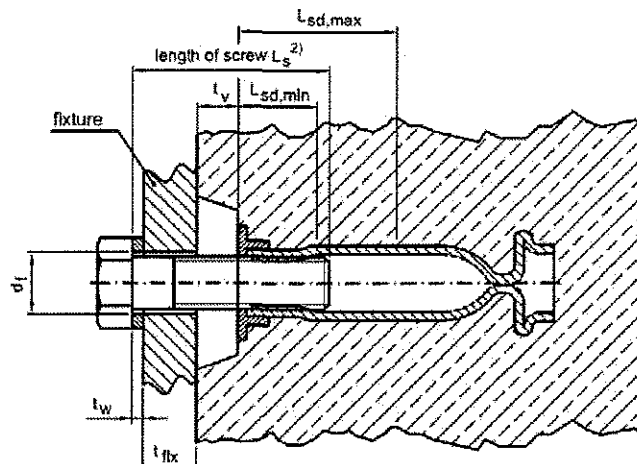

$$2) t_w + t_{fix} + t_v + L_{sd,min} \leq L_s \leq t_w + t_{fix} + t_v + L_{sd,max}$$

Table 4: Installation parameters

Thread	d	[mm]	M10	M12	M16	M20
Maximum torque moment	max. T _{inst}	[Nm]	≤ 8	≤ 10	≤ 30	≤ 60
Minimum screw-in length	L _{sd,min}	[mm]	17.0	20.0	26.0	32.0
Maximum screw-in length	L _{sd,max}	[mm]	32.0	M12x50: 30.0	M16x60: 32.0	M20x70: 44.0
				M12x70: 38.0	M16x80: 50.0	M20x100: 62.0
				M12x95: 38.0	M16x100: 50.0	M20x125: 62.0
				M12x115: 38.0	M16x110: 50.0	M20x145: 62.0
Diameter of clearance hole in fixture	d _f	[mm]	12.0	14.0	18.0	22.0

DEMU Fixing anchor T-FIXX

Installation parameters

Annex 4

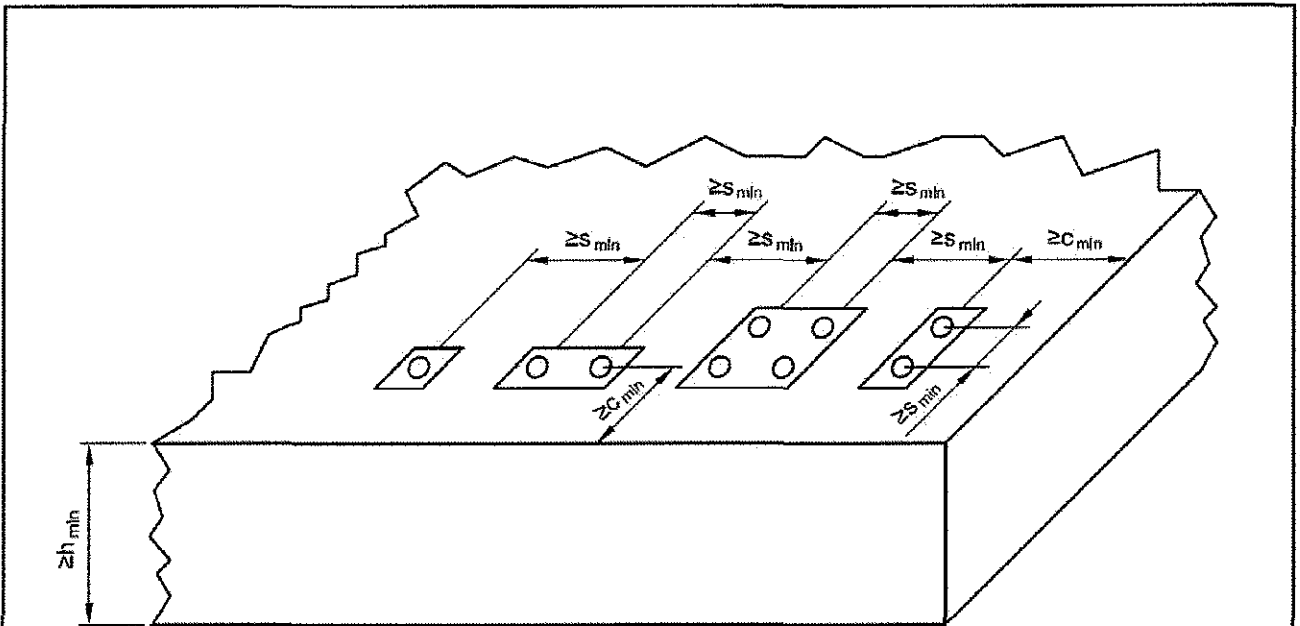

The mentioned spacings, edge distances and member thicknesses apply also for fixing anchors installed in the front edge.

Table 5: Min. allowed thickness of concrete member, min. edge distances and spacing

Thread	d	[mm]	M10	M12	M16	M20
Minimum spacing	s_{min}	[mm]	100	100	100	120
Minimum edge distance	c_{min}	[mm]	50	50	50	60
Minimum thickness of concrete member	h_{min}	[mm]	$h_{nom} + c_{nom}^{1)}$			
¹⁾ c_{nom} acc. EN 1992-1 with $c_{nom} \geq 20\text{mm}$ For fixing anchors made of stainless steel a minimum concrete cover $c_{nom} = 20\text{mm}$ is sufficient.						

DEMU Fixing anchor T-FIXX

Arrangement of anchors and member thickness

Annex 5

Table 6: Characteristic values for tension loads

Thread	d	[mm]	M10	M12	M16	M20	
Steel failure, fixing anchor and screw (min. steel strength 4.6, 5.6 or 8.8) made of galvanised steel							
Characteristic resistance	$N_{Rk,s}$	[kN]	17.5	29.2	47.4	61.4	
Partial safety factor	$\gamma_{Ms}^{1)}$	[-]	1.74				
Steel failure, fixing anchor and screw (min. steel strength A4-50) made of stainless steel							
Characteristic resistance	$N_{Rk,s}$	[kN]	24.9	42.2	69.7	90.3	
Partial safety factor	$\gamma_{Ms}^{1)}$	[-]	2.79	2.86	2.79		
Steel failure, fixing anchor and screw (min. steel strength A4-70 or A4-80) made of stainless steel							
Characteristic resistance	$N_{Rk,s}$	[kN]	24.9	43.5	69.7	90.3	
Partial safety factor	$\gamma_{Ms}^{1)}$	[-]	2.79				
Pull-out failure							
Fixing anchor electrolytically galvanised							
Charact. resistance in cracked concrete	C20/25	$N_{Rk,p}$	[kN]	17.1	28.3	46.3	56.6
Charact. resistance in uncracked concrete	C20/25	$N_{Rk,p}$	[kN]	24.0	39.6	64.8	79.2
Fixing anchor in stainless steel							
Charact. resistance in cracked concrete	C20/25	$N_{Rk,p}$	[kN]	13.8	27.5	38.9	47.0
Charact. resistance in uncracked concrete	C20/25	$N_{Rk,p}$	[kN]	19.3	38.5	54.5	65.7
Increasing factors for $N_{Rk,p}$ in cracked and uncracked concrete	C25/30	ψ_c	[-]	1.20			
	C30/37	ψ_c	[-]	1.48			
	C35/45	ψ_c	[-]	1.80			
	C40/50	ψ_c	[-]	2.00			
	C45/55	ψ_c	[-]	2.20			
	C50/60	ψ_c	[-]	2.40			
Partial safety factor		$\gamma_{Mp}^{1)}$	[-]	1.50			
Concrete cone failure							
Effective anchorage depth	h_{ef}	[mm]	M10x50: 43.7	M12x50: 42.5	M16x60: 51.3	M20x70: 61.2	
			M10x65 ²⁾ : 58.7	M12x70: 62.5	M16x80 ²⁾ : 71.3	M20x100: 91.2	
			M10x75 ³⁾ : 68.7	M12x95 ³⁾ : 87.5	M16x100 ³⁾ : 91.3	M20x125 ²⁾ : 116.2	
				M12x115 ²⁾ : 107.5	M16x110 ²⁾ : 101.3	M20x145 ³⁾ : 136.2	
Factor to take into account the influence of load transfer mechanisms in cracked and uncracked concrete	k_{Cr}	[-]	8.5				
	k_{Ucr}	[-]	11.9				
Characteristic spacing	$s_{Cr,N}$	[mm]	3.0 · h_{ef}				
Characteristic edge distance	$c_{Cr,N}$	[mm]	1.5 · h_{ef}				
Partial safety factor		$\gamma_{Mc}^{1)}$	[-]	1.50			
Splitting							
Verification of splitting is not relevant ⁴⁾							
¹⁾ in absence of other national regulations; ²⁾ only stainless steel; ³⁾ only galvanised steel							
⁴⁾ reinforcement to resist splitting forces acc. to CEN/TS 1992-4-2:2009, section 6.2.6.2 b)							

Table 7: Displacements under tension loads

Thread	d	[mm]	M10	M12	M16	M20
Tension load	N	[kN]	7	12	19	25
Short time displacements	δ_{N0}	[mm]	0.3	0.5	0.3	0.2
Long time displacements	$\delta_{N\infty}$	[mm]	0.6	1.0	0.6	0.4

DEMU Fixing anchor T-FIXX

Characteristic values for tension loads
Displacements under tension loads

Annex 6

Table 8: Characteristic values for shear loads						
Thread	d	[mm]	M10	M12	M16	M20
Shear loads without lever arm						
group factor (CEN/TS 1992-4-2, 6.3.3.1)	k_2	[-]	1,0			
Steel failure, fixing anchor and screw (min. steel strength 4,6, 5,6 or 8,8) made of galvanised steel						
Characteristic resistance	$V_{Rk,s}$	[kN]	8,8	14,6	23,7	30,7
Partial safety factor	$\gamma_{Ms}^{1)}$	[-]	1,45			
Steel failure, fixing anchor and screw (min. steel strength A4-50) made of stainless steel						
Characteristic resistance	$V_{Rk,s}$	[kN]	12,5	21,1	34,8	45,1
Partial safety factor	$\gamma_{Ms}^{1)}$	[-]	2,33	2,38	2,33	
Steel failure, fixing anchor and screw (min. steel strength A4-70 or A4-80) made of stainless steel						
Characteristic resistance	$V_{Rk,s}$	[kN]	12,5	21,8	34,8	45,1
Partial safety factor	$\gamma_{Ms}^{1)}$	[-]	2,33			
Shear loads with lever arm						
Steel failure, fixing anchor and screw (min. steel strength 4,6) made of galvanised steel						
Characteristic resistance	$M_{Rk,s}^0$	[Nm]	29,9	52,4	133,2	259,6
Partial safety factor	$\gamma_{Ms}^{1)}$	[-]	1,67			
Steel failure, fixing anchor and screw (min. steel strength 5,6) made of galvanised steel						
Characteristic resistance	$M_{Rk,s}^0$	[Nm]	37,4	65,5	166,5	324,5
Partial safety factor	$\gamma_{Ms}^{1)}$	[-]	1,67			
Steel failure, fixing anchor and screw (min. steel strength 8,8) made of galvanised steel						
Characteristic resistance	$M_{Rk,s}^0$	[Nm]	68,9	104,8	263,8	541,4
Partial safety factor	$\gamma_{Ms}^{1)}$	[-]	1,45	1,25	1,45	
Steel failure, fixing anchor and screw (min. steel strength A4-50) made of stainless steel						
Characteristic resistance	$M_{Rk,s}^0$	[Nm]	37,4	65,5	166,5	324,5
Partial safety factor	$\gamma_{Ms}^{1)}$	[-]	2,38			
Steel failure, fixing anchor and screw (min. steel strength A4-70) made of stainless steel						
Characteristic resistance	$M_{Rk,s}^0$	[Nm]	52,3	91,7	233,1	454,4
Partial safety factor	$\gamma_{Ms}^{1)}$	[-]	1,56			
Steel failure, fixing anchor and screw (min. steel strength A4-80) made of stainless steel						
Characteristic resistance	$M_{Rk,s}^0$	[Nm]	101,3	104,8	388,0	796,2
Partial safety factor	$\gamma_{Ms}^{1)}$	[-]	2,33	1,33	2,33	
Pry-out failure						
Factor	k_3	[-]	M10x50: 1,0 M10x65 ²⁾ : 1,0 M10x75 ³⁾ : 2,0	M12x50: 1,0 M12x70: 2,0 M12x95 ³⁾ : 2,0 M12x115 ²⁾ : 2,0	M16x60: 1,0 M16x80 ²⁾ : 2,0 M16x100 ³⁾ : 2,0 M16x110 ²⁾ : 2,0 M16x125 ³⁾ : 2,0	M20x70: 1,0 M20x100: 2,0 M20x125 ²⁾ : 2,0 M20x145 ³⁾ : 2,0
Partial safety factor	$\gamma_{Mcp}^{1)}$	[-]	1,50			
Concrete edge failure (without suppl. reinforcement)						
Effective length of fixing anchor (for shear loads)	l_f	[mm]	M10x50: 30,0 M10x65 ²⁾ : 45,0 M10x75 ³⁾ : 55,0	M12x50: 29,0 M12x70: 49,0 M12x95 ³⁾ : 74,0 M12x115 ²⁾ : 81,4	M16x60: 37,0 M16x80 ²⁾ : 57,0 M16x100 ³⁾ : 77,0 M16x110 ²⁾ : 87,0 M16x125 ³⁾ : 102,0	M20x70: 46,0 M20x100: 76,0 M20x125 ²⁾ : 101,0 M20x145 ³⁾ : 121,0
Effective outside diameter	d_{nom}	[mm]	13,5	17,0 / 17,2 ⁴⁾	21,3	26,9
Partial safety factor	$\gamma_{Mce}^{1)}$	[-]	1,50			

¹⁾ in absence of other national regulations; ²⁾ only stainless steel; ³⁾ only galvanised steel; ⁴⁾ higher value applies for stainless steel

Table 9: Displacements under shear loads

Thread	d	[mm]	M10	M12	M16	M20
Shear load	V	[kN]	13	19	24	28
Short time displacements	δ_{V0}	[mm]	2,0	2,0	2,0	3,0
Long time displacements	δ_{Vw}	[mm]	3,0	3,0	3,0	4,5

DEMU Fixing anchor T-FIXX

Characteristic values for shear loads
Displacements under shear loads

Annex 7

Installation instruction - part 1

1. Scope of delivery



1) Selection of fixing anchor in accordance with the planning documents.

1a) DEMU T-FIXX made of galvanised steel (GV) or stainless steel (A4)

1b) Data clip for T-FIXX GV, colour: grey
Data clip for T-FIXX A4, colour: white

2. Fixing of the anchor to the formwork

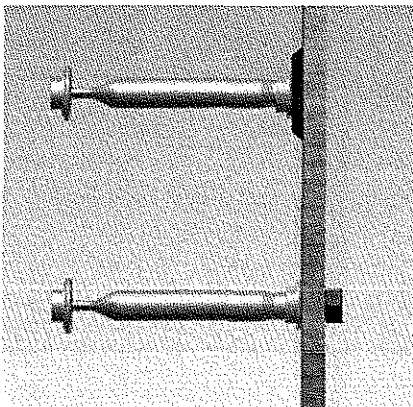

1) Attach data clip to the fixing anchor.

2) Fix the anchor to the formwork with the help of DEMU assembly accessories (e. g. nailing plate) or alternatively by hexagon bolts.

→ The inside of the threaded socket must be protected against ingress of dirt and water.

3) If necessary, supplementary reinforcement has to be placed according to the planning documents.

3. Pouring and compacting of concrete

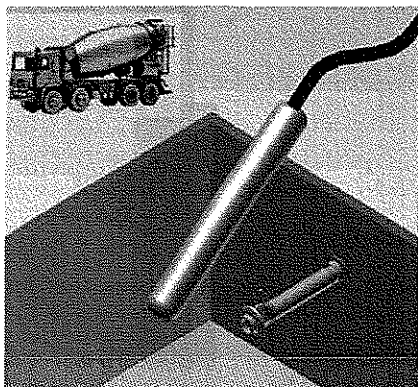

1) Pour concrete carefully, make sure the anchor stays in place!

2) Compact concrete carefully, avoid direct contact between compacting device and anchor.

→ The anchor must not be moved by force or damaged!

DEMU Fixing anchor T-FIXX

Installation instruction – part 1

Annex 8

Installation instruction - part 2

4. Hardening of the concrete, striking the formwork

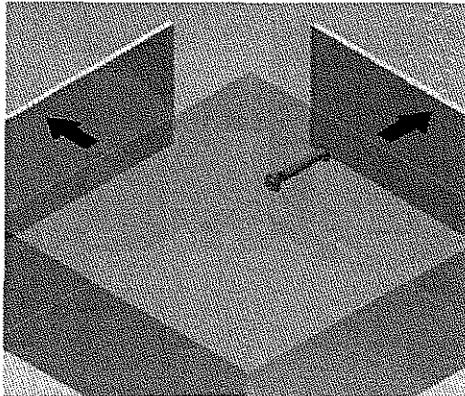

- 1) Remove assembly accessories and formwork.
- 2) Check if the inside of the threaded socket is free from dirt, otherwise clean it; further protection against ingress of water, dirt, etc. until required for use.

5. Mounting of fixture

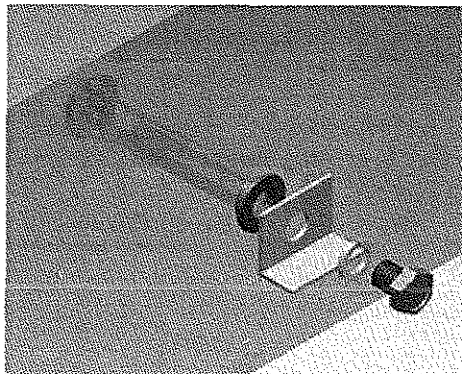

- 1) Make sure that the concrete has reached its final strength.
- 2) Check the length of the required bolt.
→ Maximum / minimum screw-in length according Annex 4!
- 3) Mounting of the fixture
→ Use fixing components according Annex 3, Table 3.
→ Maximum torque moments, see table below!
→ Take additionally care of assembly advices for the fixture.

6. Maximum torque moments

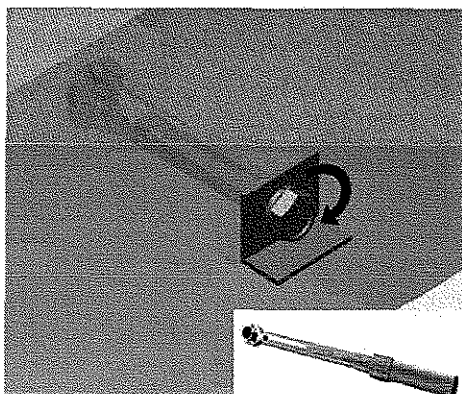

Apply torque moment with the help of a torque wrench.
 T_{inst} must not be exceeded.

Maximum torque moment T_{inst}						
Thread	d	[mm]	M10	M12	M16	M20
Max. torque moment	max. T_{inst}	[Nm]	≤ 8	≤ 10	≤ 30	≤ 60

DEMU Fixing anchor T-FIXX

Installation instruction – part 2

Annex 9

CONTACT HALFEN WORLDWIDE

HALFEN is represented by subsidiaries in the following 14 countries, please contact us:

Austria	HALFEN Gesellschaft m.b.H. Leonard-Bernstein-Str. 10 1220 Wien	Phone: +43-1-259 6770 E-Mail: office@halfen.at Internet: www.halfen.at	Fax: +43-1-259-677099
Belgium/ Luxembourg	HALFEN N.V. Borkelstraat 131 2900 Schoten	Phone: +32-3-658 07 20 E-Mail: info@halfen.be Internet: www.halfen.be	Fax: +32-3-658 15 33
China	HALFEN Construction Accessories Distribution Co.Ltd. Room 601 Tower D, Vantone Centre No. A6 Chao Yang Men Wai Street Chaoyang District Beijing · P.R. China 100020	Phone: +86-10 5907 3200 E-Mail: info@halfen.cn Internet: www.halfen.cn	Fax: +86-10 5907 3218
Czech Republic	HALFEN-DEHA s.r.o. Business Center Šafránkova Šafránkova 1238/1 155 00 Praha 5	Phone: +420-311-690 060 E-Mail: info@halfen-deha.cz Internet: www.halfen-deha.cz	Fax: +420-235-314 308
France	HALFEN S.A.S. 18, rue Goubet 75019 Paris	Phone: +33-1- 445231 00 E-Mail: halfen@halfen.fr Internet: www.halfen.fr	Fax: +33-1-44523152
Germany	HALFEN Vertriebsgesellschaft mbH Katzbergstrasse 3 40764 Langenfeld	Phone: +49-2173-970-0 E-Mail: info@halfen.de Internet: www.halfen.de	Fax: +49-2173-970 225
Italy	HALFEN S.r.l. Soc. Unipersonale Via F.lli Bronzetti N° 28 24124 Bergamo	Phone: +39-035-0760711 E-Mail: info@halfen.it Internet: www.halfen.it	Fax: +39-035-0760799
Netherlands	HALFEN b.v. Oostermaat 3 7623 CS Borne	Phone: +31-742-6714 49 E-Mail: info@halfen.nl Internet: www.halfen.nl	Fax: +31-742 6726 59
Norway	HALFEN AS Postboks 2080 4095 Stavanger	Phone: +47-51 82 34 00 E-Mail: post@halfen.no Internet: www.halfen.no	Fax: +47-51 82 34 01
Poland	HALFEN Sp. z o.o. Ul. Obornicka 287 60-691 Poznan	Phone: +48-61-622 14 14 E-Mail: info@halfen.pl Internet: www.halfen.pl	Fax: +48-61-622 14 15
Sweden	Halfen AB Box 150 435 23 Mölnlycke	Phone: +46-31-98 58 00 E-Mail: info@halfen.se Internet: www.halfen.se	Fax: +46-31-98 58 01
Switzerland	HALFEN Swiss AG Hertistrasse 25 8304 Wallisellen	Phone: +41-44-849 78 78 E-Mail: mail@halfen.ch Internet: www.halfen.ch	Fax: +41-44-849 78 79
United Kingdom/ Ireland	HALFEN Ltd. Humphrys Road · Woodside Estate Dunstable LU5 4TP	Phone: +44-1582-47 03 00 E-Mail: info@halfen.co.uk Internet: www.halfen.co.uk	Fax: +44-1582-47 03 04
United States of America	HALFEN USA Inc. 8521 FM 1976 P.O. Box 547 Converse, TX 78109	Phone: +1 800.423.91 40 E-Mail: info@halfenusa.com Internet: www.halfenusa.com	Fax: +1 877.683.4910
For countries not listed HALFEN International	HALFEN International GmbH Liebigstr. 14 40764 Langenfeld /Germany	Phone: +49-2173-970-0 E-Mail: info@halfen.com Internet: www.halfen.com	Fax: +49-2173-970-849

Furthermore HALFEN is represented with sales offices and distributors worldwide. Please contact us: www.halfen.com

NOTES REGARDING THIS CATALOGUE

Technical and design changes reserved. The information in this publication is based on state-of-the-art technology at the time of publication. We reserve the right to make technical and design changes at any time. HALFEN GmbH shall not accept liability for the accuracy of the information in this publication or for any printing errors.

The Quality Management System of Halfen GmbH is certified for the locations in Germany, France, the Netherlands, Austria, Poland, Switzerland and the Czech Republic according to **DIN EN ISO 9001:2008**, Certificate No. QS-281 HH.





For further information please contact: www.halfen.com